

BLASTING CHAMBER / ROOM



ECHOSWIFT Modular Blast Room is specially ventilated and illuminated for enclosed abrasive blasting. The components are prefabricated for simple bolt-together erection, with little or no job site welding required. The Blasting Chamber can be easily dismantled and for transportation and easy to reinstall.

ECHOSWIFT provide Auto Blasting System (Abrasive Recovery and manual abrasive recovery).

There is a selection of chambers available with different sizes of work space and with numerous optional accessories which allow us to adjust our chambers to the needs of even the most demanding customer.

ECHOSWIFT provides engineering, consultation, supply and install Blasting Chamber to comply with Factories and Machinery (Mineral Dust) Regulations 1989 and USECHH Regulations 2000 under Department of Safety and Health (DOSH) and Environmental Quality (Clean Air) Regulations, 2014 under Department of



How It Work

Used abrasive is allowed to collect on the floor of the chamber.

At the conclusion of blasting the used abrasive is manually shoveled into containers.

Used abrasive is manually fed onto the bucket elevator and then into the Airstream Abrasive Cleaning Chamber.

- Minimal Capital Cost
- Abrasive is still effectively cleaned for recycling
- No loss in blasting effectiveness

Auto Abrasive Recovery (Scrapper Type)

How It Work: Used abrasive media falls down into the scrapper unit from where it is conveyed by longitudinal scrapper conveyors to cross scrapper conveyor. The cross scrapper conveyor conveys the abrasive media into bucket elevator. The bucket elevator lifts the media and pours into media separation unit from where the reusable abrasive goes into the Portable Abrasive Blaster and Abrasive is recycled through blast nozzle. The unusable abrasive from the media separator unit is collect-

Ideal for large chambers with high volumes of work

The chamber floor is made from heavy grade steel grating

Benefit of Continuous Auto Abrasive Recovery (Scrapper Type)

- Eliminates abrasive clean up time when high blasting volumes are required.
- Eliminates down time due clogging and blockage of used abrasive within the system.
- Reduce energy requirements
- Reduced maintenance cost
- Longer operating life



Screw Conveyor



Scrapper



Floor Recovery System



Raising Floor

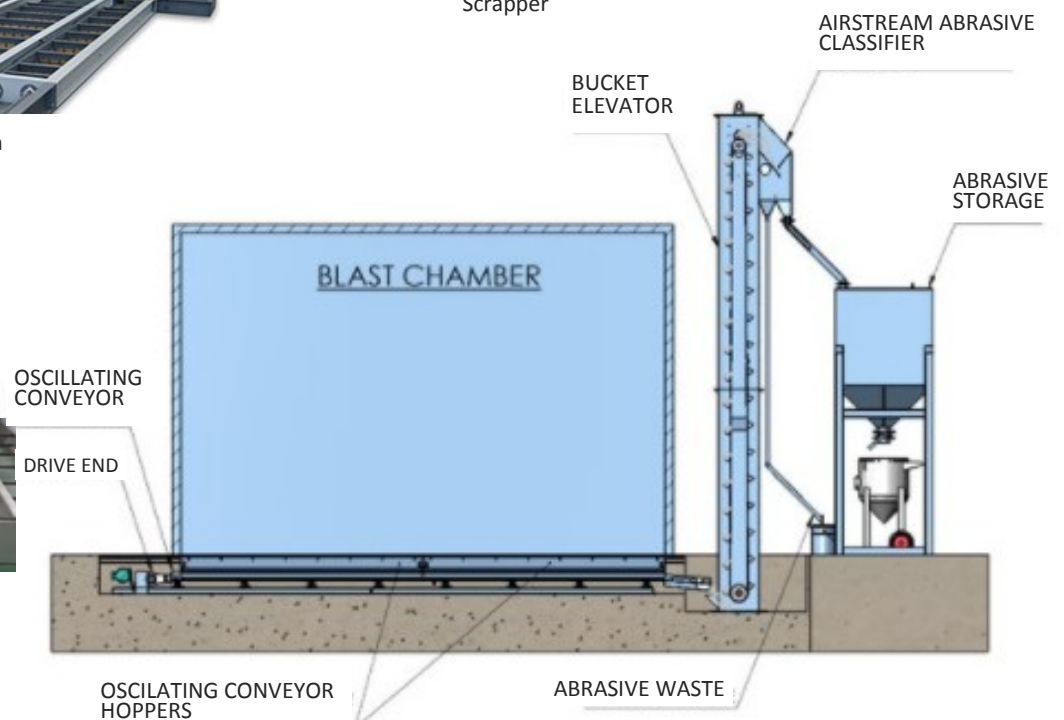

Dust Collector



ECHOSWIFT Dust Collector Cartridge Type delivers outstanding performance to meet air quality needs across many applications. Backed by a limited 18 months warranty, engineered with reliability and simplicity, Dust collector produces the air quality you need year after year with easy maintenance. Available options and accessories ensure can be tailored to meet a wide array of applications. Pulse-jet

ECHOSWIFT DUST COLLECTOR APPLICATION

<u>Metalworking</u> Grinding/ Polishing	<u>Industrial Processing</u> Plastics/ Rubber Paint Pigments	<u>Food Processing</u> Flour and Mixes Chocolate/ Cocoa	<u>Pharmaceutical</u> Packaging Tablet Presses
<u>Woodworking</u>			

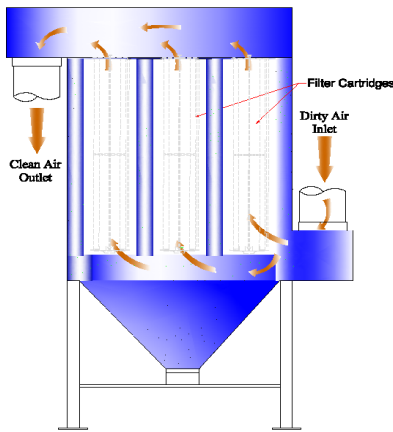

During normal operations, dirty air enters the side of the dust collector and moves upward through the filter cartridge, leaving dust on the outer surface of the cartridge element. Clean air exits through the center of the cartridge to the plenum and exits the unit. Pulse-jet technology, controlled by a programmable

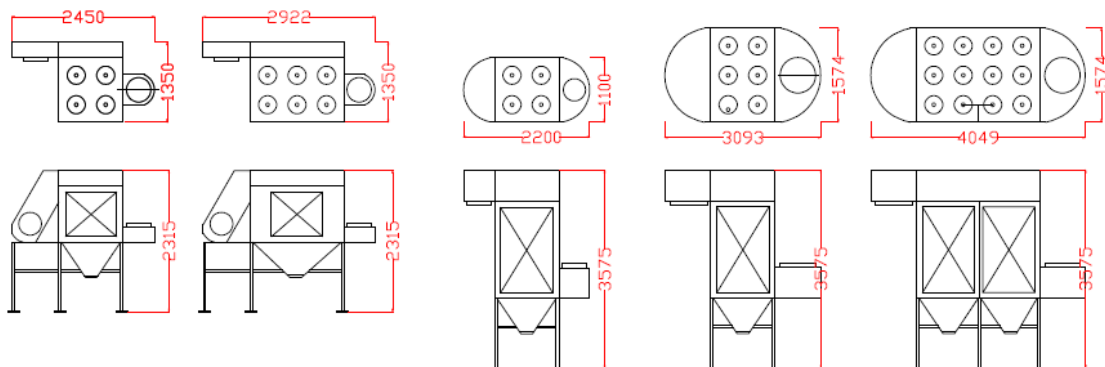

SPECIFICATION	ECHOSWIFT DUST COLLECTOR MODEL						
	DC 4S	DC 6S	DC 4D	DC 6D	DC 9D	DC 12D	DC 20D
Air Flow (cfm)	2400	3600	5000	8000	11 000	15 000	24 000
Type	Portable					Fix	
Filter	Polypropylene/ Polyester/ Cellulose paper						

Note : - Portable by (forklift / crane) / Unit complete with centrifugal fan, electrical panel and pulse jet controller

Design

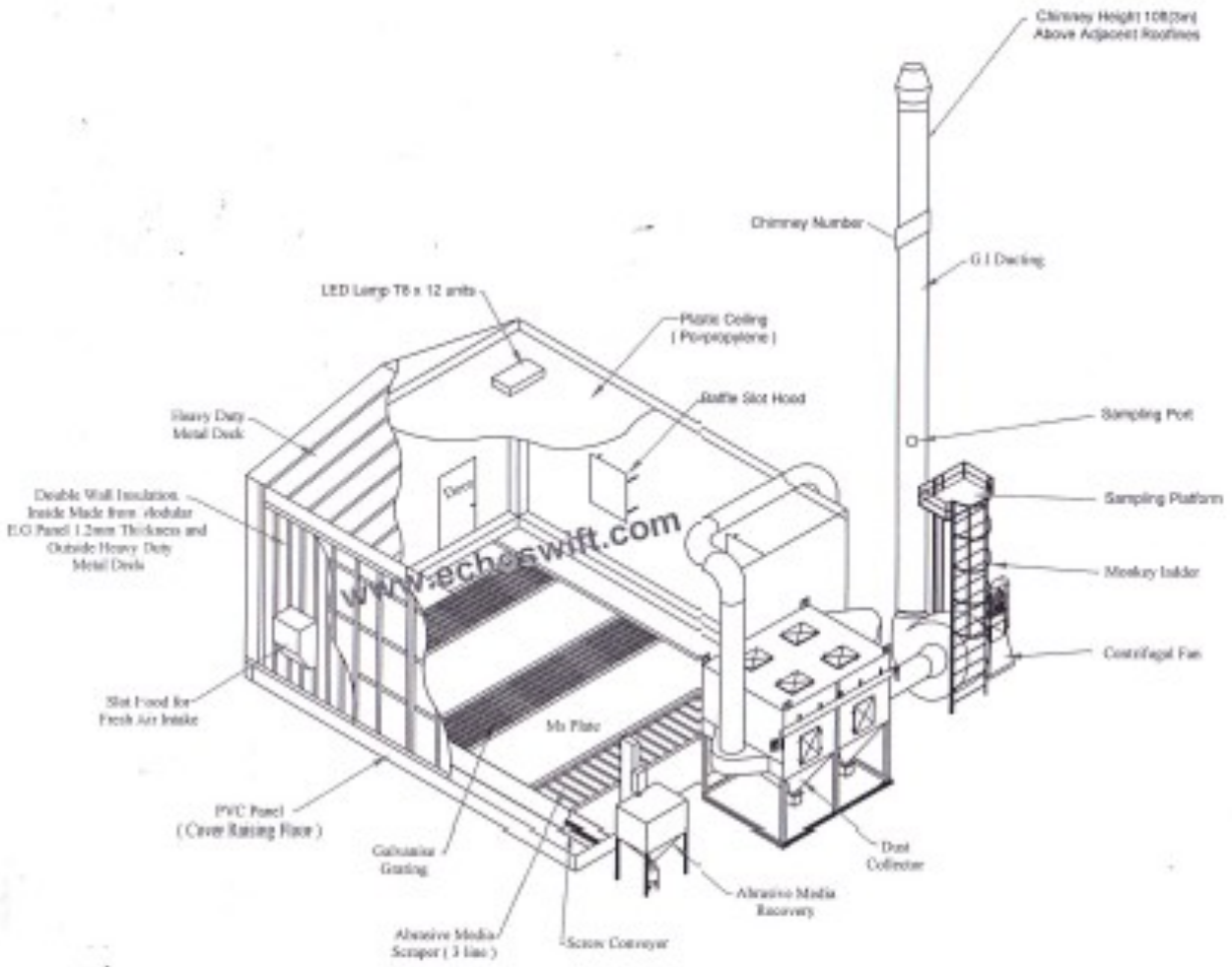

Terengganu (HQ)

Lot PT 14293 (Plot A), Kawasan Perindustrian Batu 7,
23000 Dungun, Terengganu Darul Iman.

Phone no.: 09-8490046 Fax. No.: 09-8490032 e-mail: echos@echoswift.com

Selangor (Branch)

BE-1-7A Jalan Pinggiran 1/4, Taman Pinggiran Putra,
43300 Seri Kembangan, Selangor Darul Ehsan.

Phone: 012-9887600 email : echoswift@yahoo.com